

Mon Dak Energy Alliance



Mon Dak Energy Alliance



WHY

Co-Locate

All These Projects?

Mon Dak
Energy Alliance

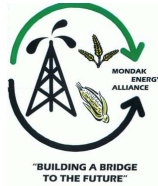

COLOCATION OF PROJECTS PRESENTATION

August 20, 2009



Global Thinking...Global Solutions™

Types of Facilities - Considered

- Coal to Jet Fuel
- Petroleum Refinery
- Power Generation
- Wind Energy
- Corn Refining - Ethanol
- Biodiesel



Raw Materials

- Coal
- Crude Oil
- Wind
- Corn
- Vegetable Oil and Fats



Primary Infrastructure Required

- Land
- Water
- Transportation
- Road-Rail
- Pipelines
- Power
- Fuel Gas
- Markets

Secondary Infrastructure

- High Pressure Steam
- Wastewater Treating
- Manpower- Industrial Support Services
- Low Pressure Steam
- Marketing Infrastructure
- Multiple Pipeline Access
 - Products
 - Carbon Dioxide
 - Raw Materials

Shared Resources

- Infrastructure
- Product Marketing
- Raw Material Supply
- Transportation
- Tank Farm
- CO₂ Liquefaction
- Hydrogen Generation
- Air Separation
- Wastewater Treating
- Labor Pool
- Local Support Services

Primary Products

- Refined Petroleum Products
- Fuel Grade Ethanol
- DDGS
- Biodiesel
- Sulfuric Acid
- Aggregate
- Power
- Carbon Dioxide

Process Overview

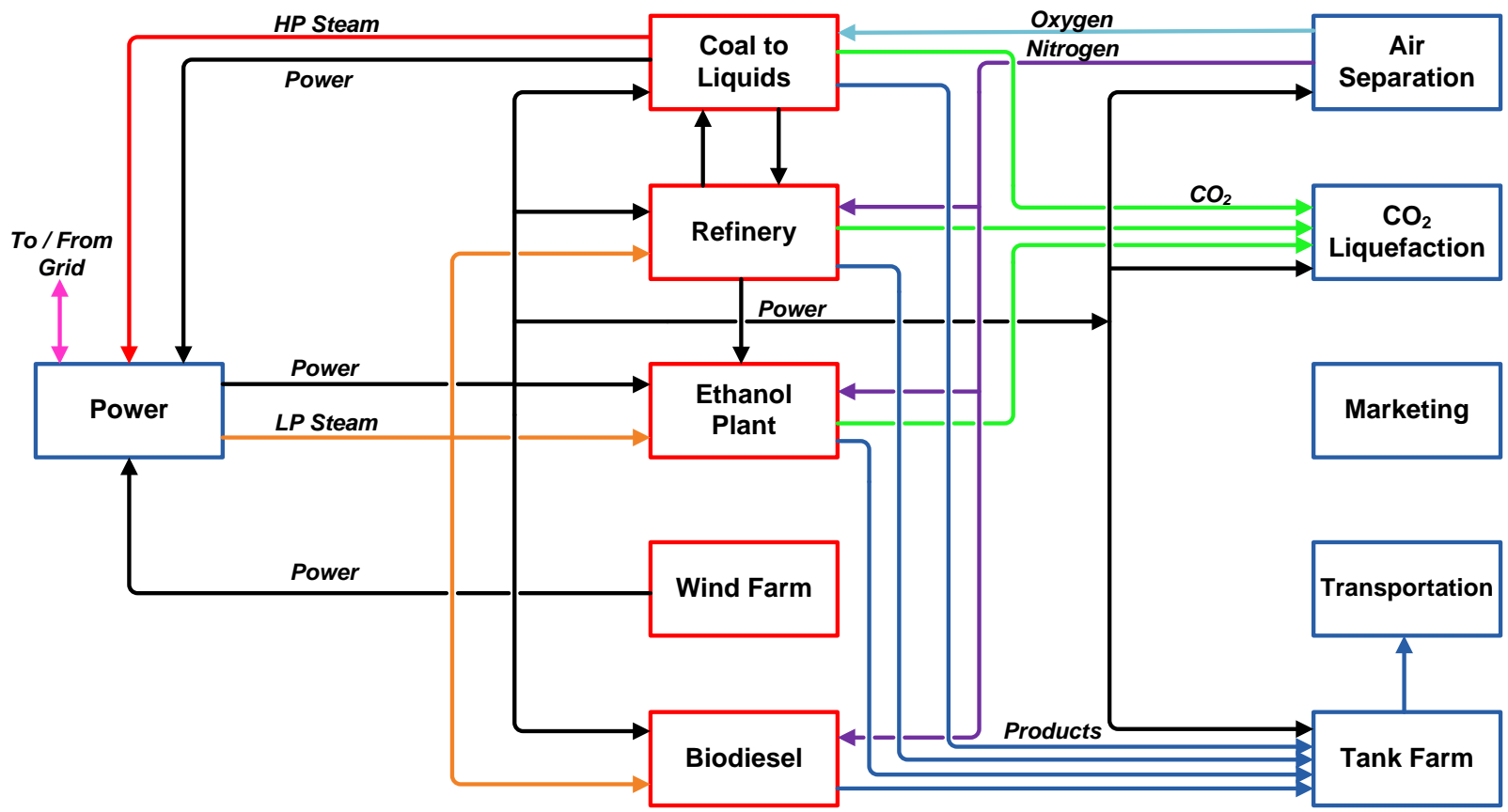

Water Utilities

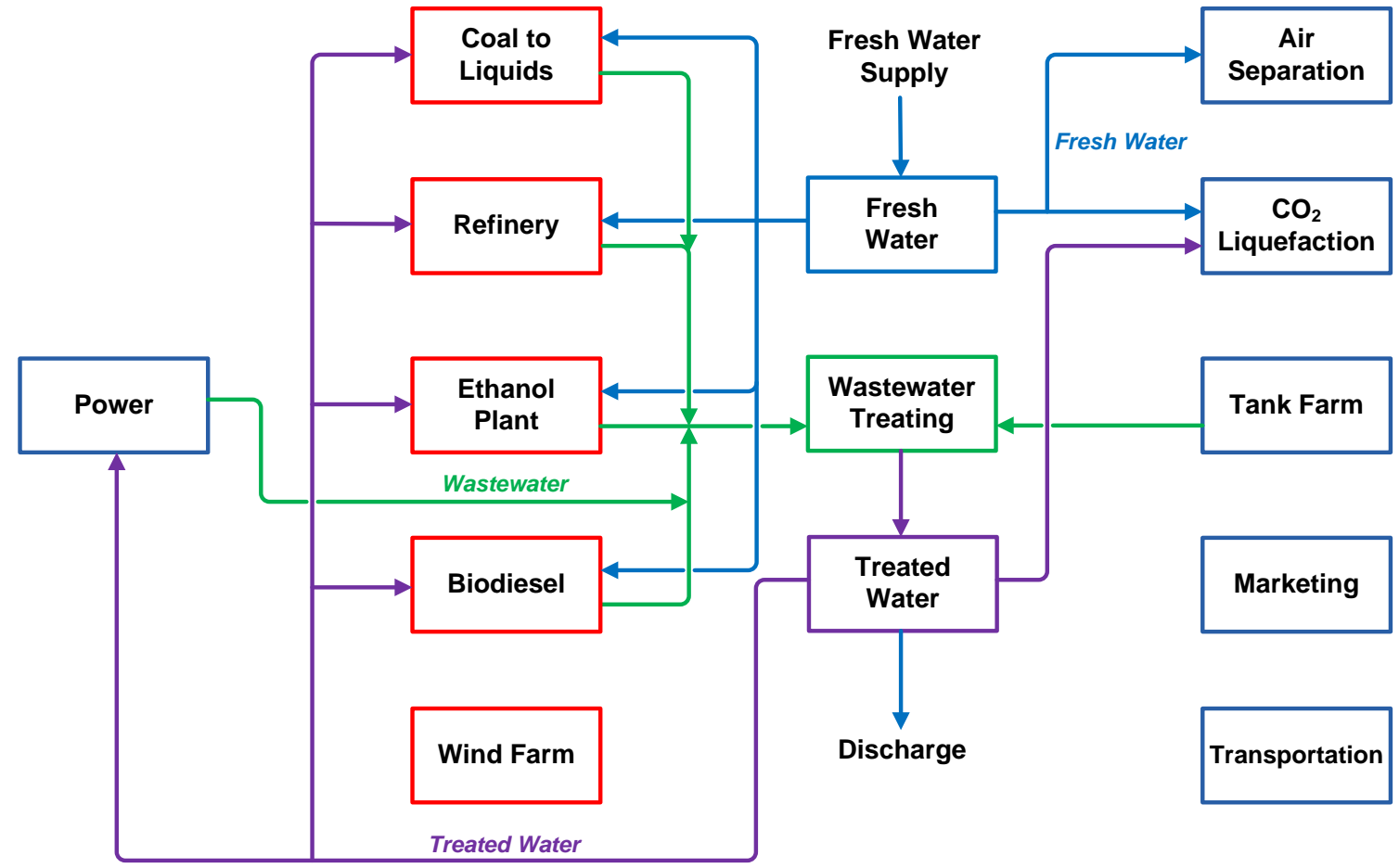

Coal to Liquids

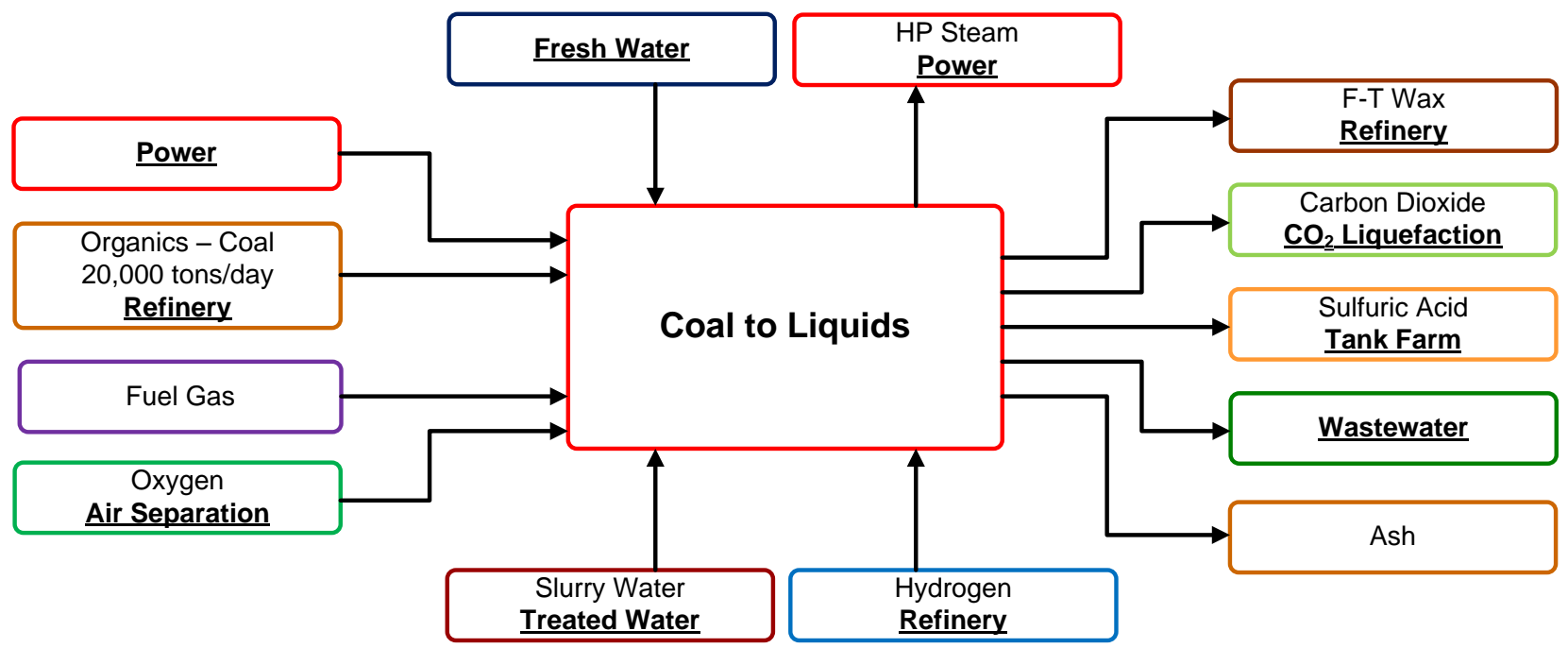

Refinery

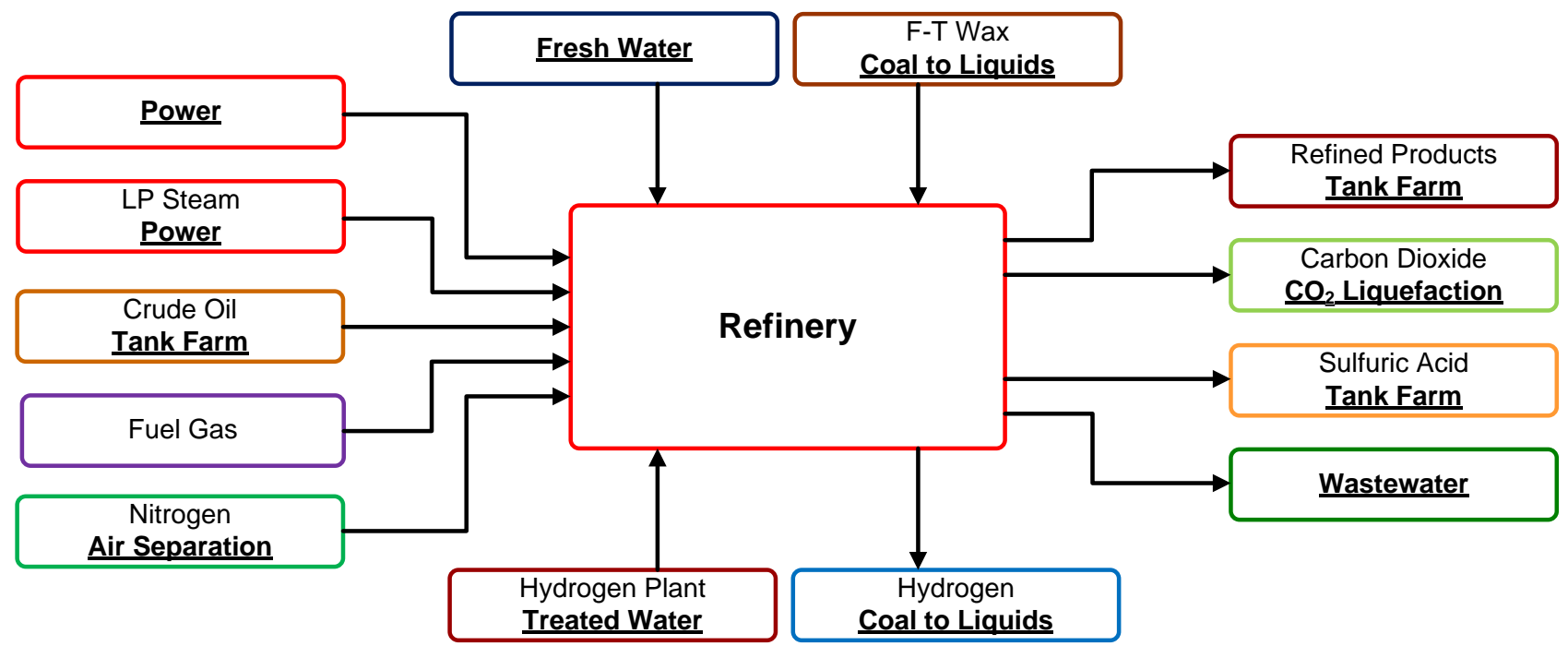

Ethanol Plant

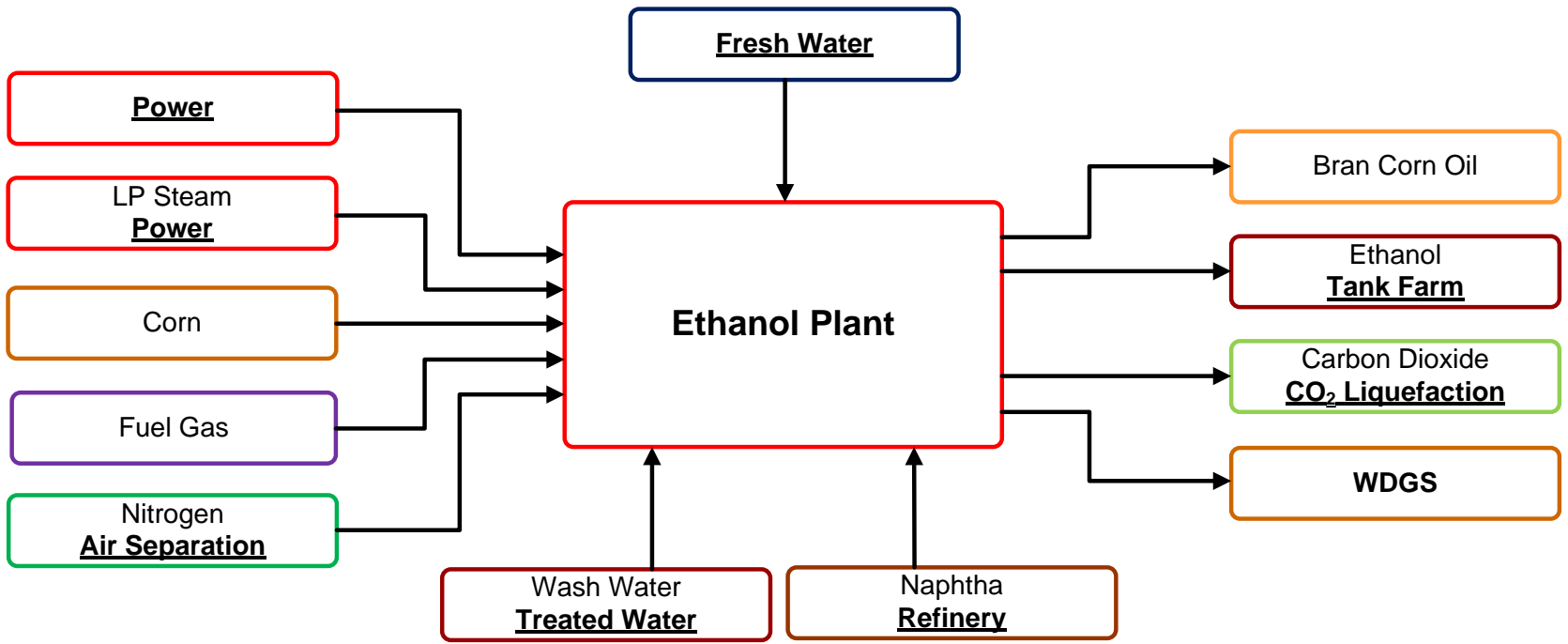

Biodiesel

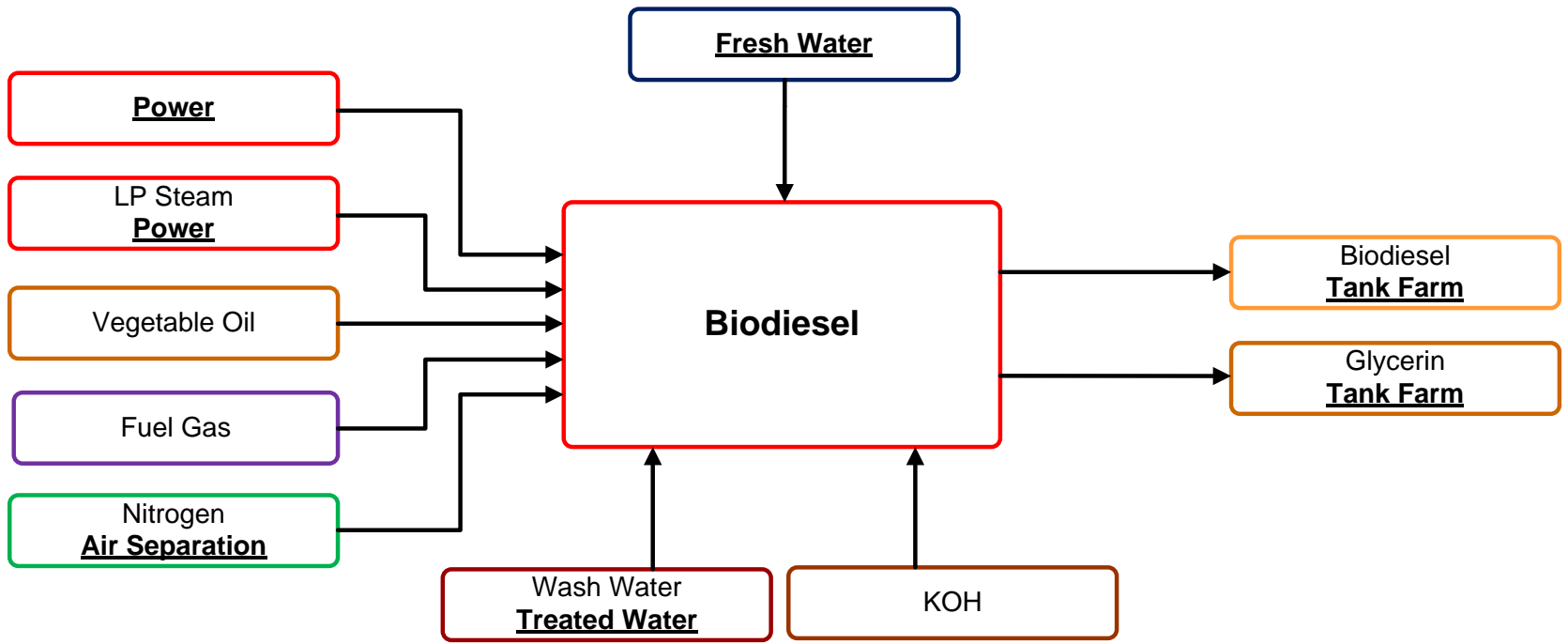

Why No New US Refineries?

- Existing Refineries were Expanded
- Expanded Refineries are Water Borne
- Economics of Existing Infrastructure
- New Crude Arrives by Water
- No New Large Oil Fields In U.S. Since Alaska

Why Small Regional US Refineries Are Idle?

- Declining Oil Fields
- Environmental Requirements
- Unable to Expand (Financial Issues)
- Limited Land
- Operating Cost
- Market Competition

What is a Topping Plant?

- A partial refinery to supply a local market
- Limited products
- Small quick to market refinery
- Minimum Investment
- Light Sweet Crude Feed
- Smaller Land Area –Tank Farm

Refinery

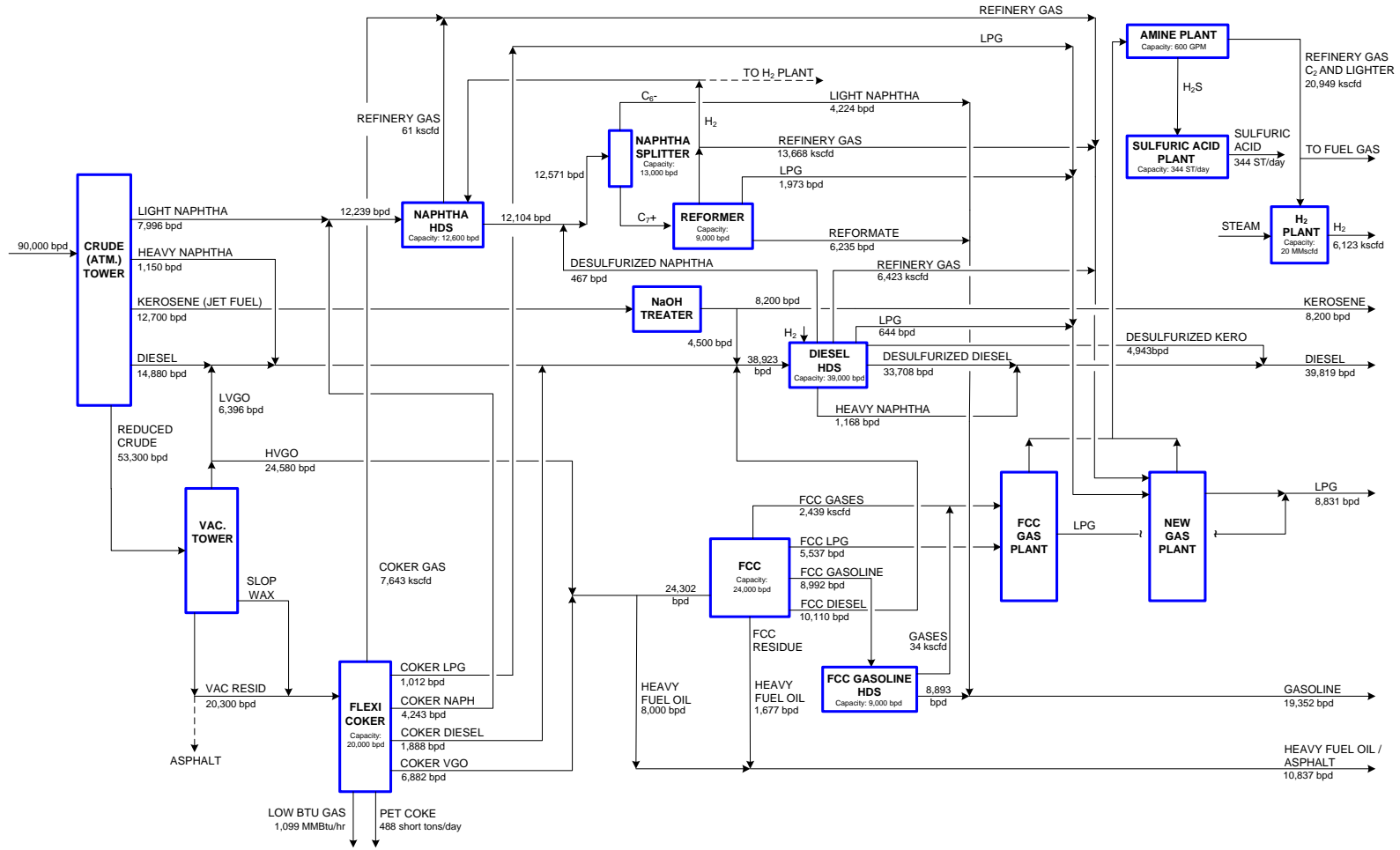

Topping Plant

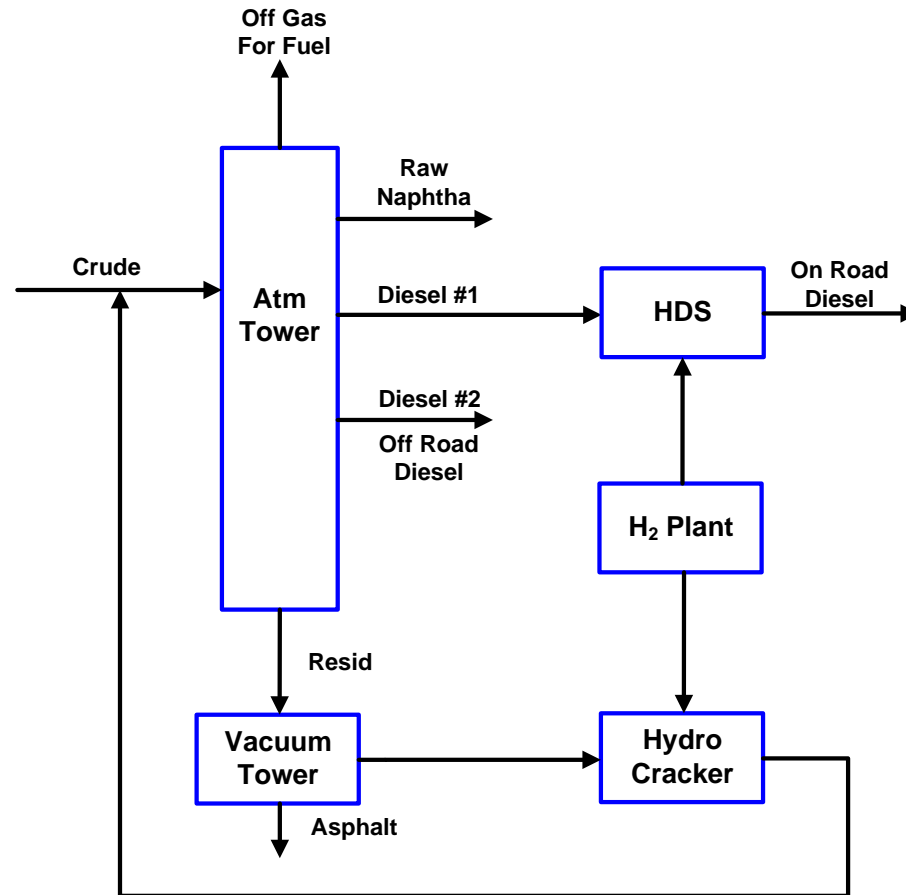

Why Williston?

- Growing Oil Fields
- Permitted
- Able to Grow
- Unlimited Land
- Local Market

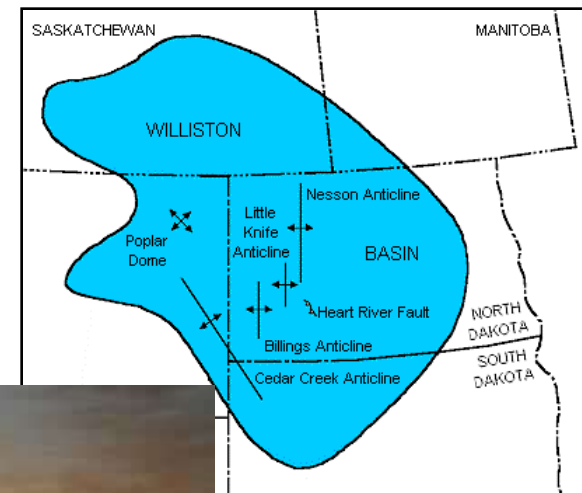

Emerging Technologies?

Proven

- Wet Sulfuric Acid (WSA)
- ROSE Unit

Developmental

- Ultra Sonic –Advanced and Funded
- FlexDS™
- High Frequency Magnetic Field
 - R & D Money and Time
 - Risk
 - Field Trials



Why Co-Locate With Complex?

- Syncrude is Hard to Ship
- H₂ is Expensive to Pipeline
- Shared Infrastructure
- Transportation
- Shared Wastewater Treating
- Water Reuse
- Synergistic Products
- Product Marketing
- Reduced Capital Costs
- Land Use Control

Mon Dak Energy Alliance

Building a Bridge to the Future

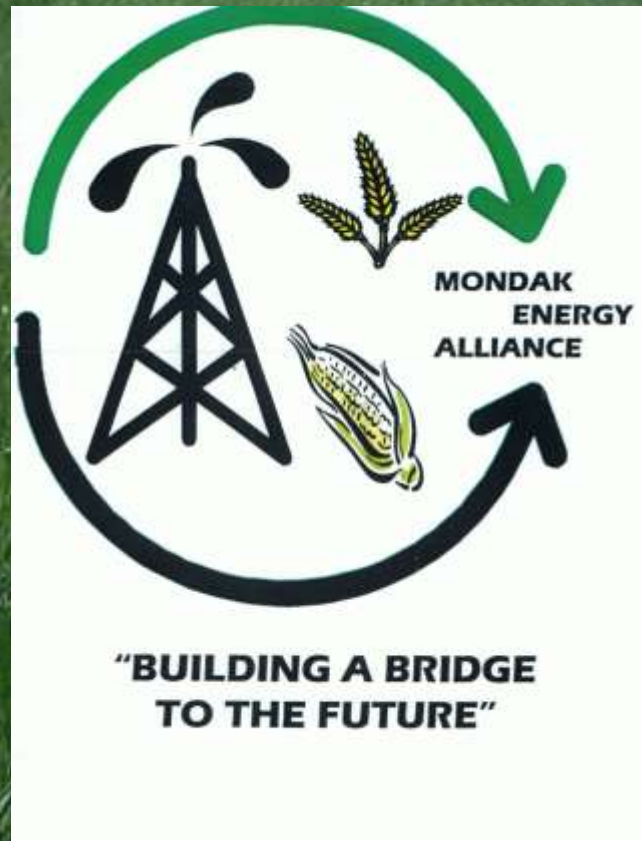

Thank you.

ENGlobal Corporation
(NASDAQ:ENG)

[Gary Reeves, P.E.](#)

Manager of Process Engineering

654 North Sam Houston Parkway East, Suite 400

Houston, TX 77060-5914

Direct: (281) 878-1063

Cell: (281) 684-2355

Fax: (281) 878-1010

gary.reeves@englobal.com

www.englobal.com